

Unbeschichtete Cermetsorten
T1000A / T1500A

T1000A - für das Hochgeschwindigkeitsschlichten

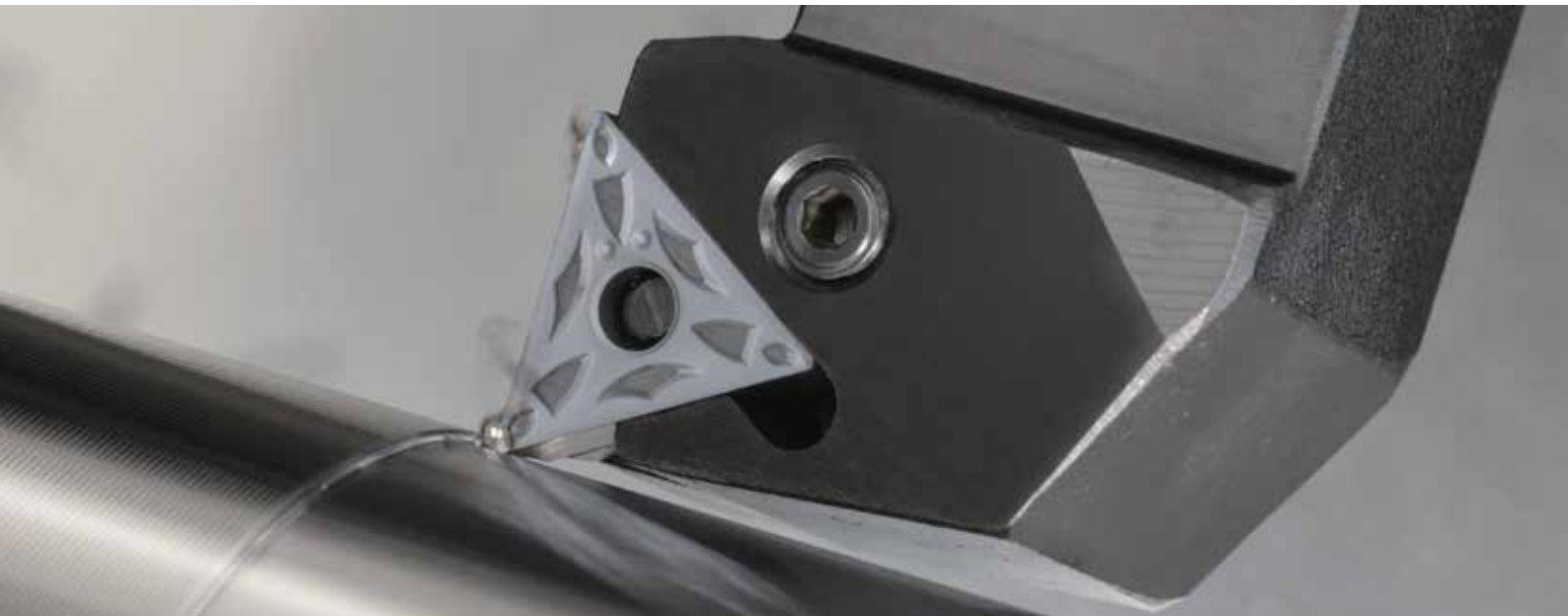

T1500A - für die allgemeine Anwendung



Unbeschichtetes Cermet T1000A / T1500A

Anwendungsbereich

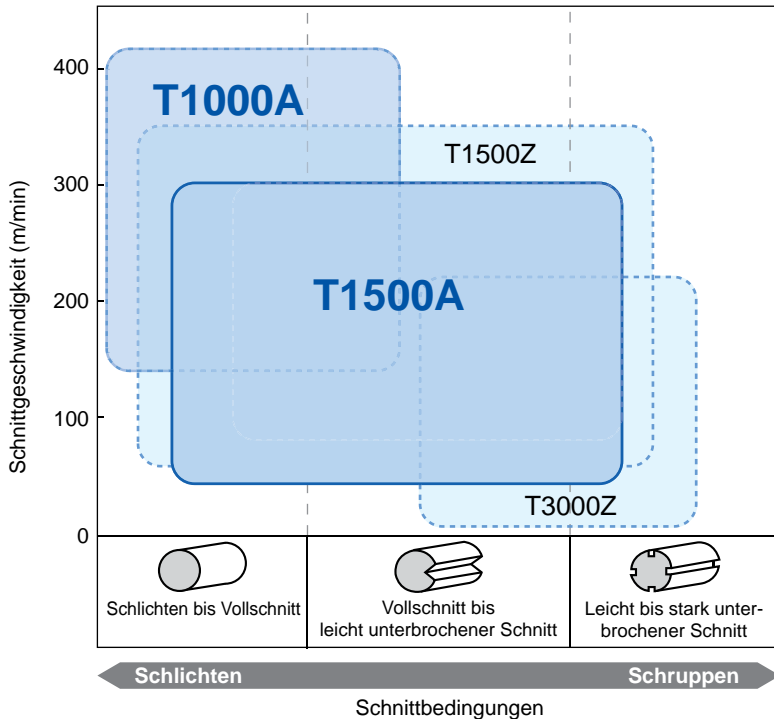

T1000A Unbeschichtet

Unbeschichtete Cermetsorte mit ausgezeichneter Verschleißfestigkeit für lange Standzeiten beim Schlichten im Vollschnitt sowie beim Konturdrehen.

T1500A Unbeschichtet

Unbeschichtetes Allzweck-Cermet mit einem ausgezeichneten Preis-Leistungsverhältnis. Es erzielt eine gute Oberflächengüte und zeichnet sich durch ein gutes Gleichgewicht zwischen Verschleiß- und Bruchfestigkeit aus.

T1500Z Beschichtet

Neue PVD-„Brilliant Coat“-Beschichtung für ausgezeichnete Bearbeitungsqualität und mit verbessertem Reibungskoeffizienten bei Drehanwendungen. Die beschichtete Cermet-Allzwecksorte erzielt exzellente Oberflächengüten und bietet eine hervorragende Verschleißfestigkeit.

T3000Z Beschichtet

Beschichtete Cermet-Sorte mit überlegener Bruchfestigkeit. Deckt eine breites Spektrum von der Schruppbearbeitung bis zum Schlichten ab.

Verwendung von Cermet-Sorten

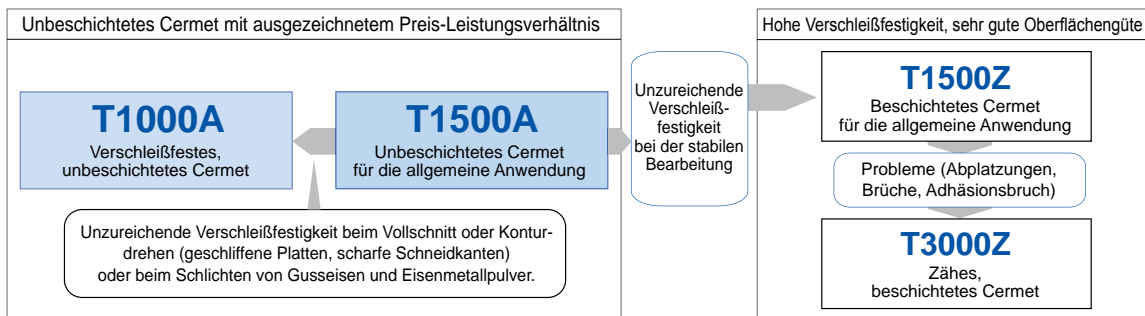

Einsatzbereiche der Spanbrecher

Negative Platten, M-Toleranz

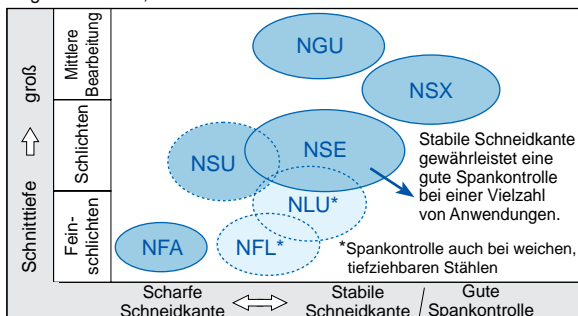

Negative Platten, G-Toleranz

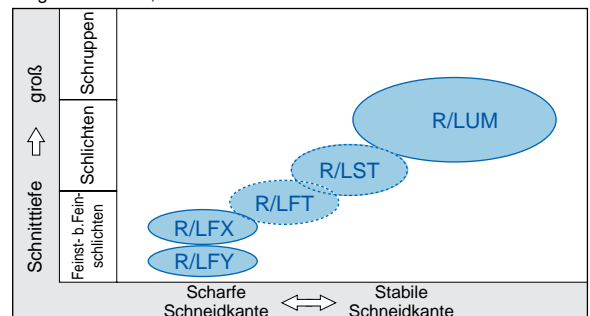

Positive Platten, M-Toleranz

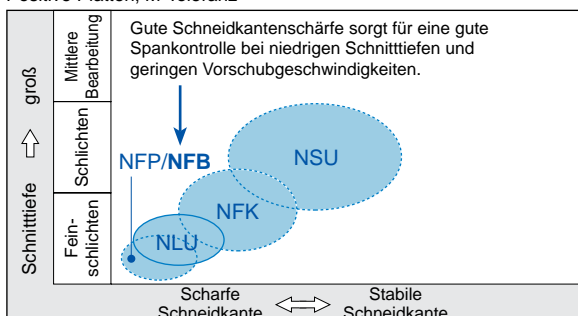

Positive Platten, G-Toleranz

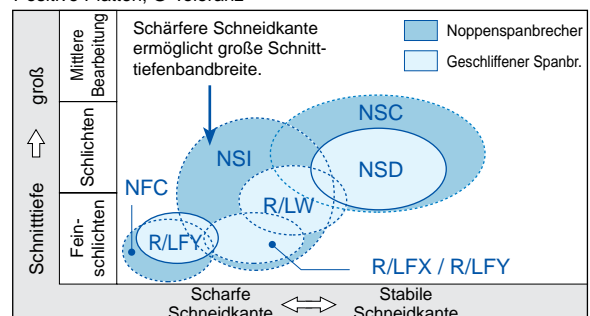

Unbeschichtetes Cermet T1000A / T1500A

T1000A - Merkmale

Unbeschichtete Cermet-Sorte mit hoher Verschleißfestigkeit, die beim Konturdrehen und bei der Hochgeschwindigkeitsbearbeitung im Vollschnitt ideal einsetzbar ist.

- Neues Substrat bestehend aus Verbund-Hart-Phasen mit einer außergewöhnlichen Zähigkeit und verbessertem Reibungskoeffizienten.
- Das Anwendungsgebiet liegt im Feinstschlichten in einem Bereich, bei dem Oberflächengüten vergleichbar mit Schleifen erreicht werden.
- Neu entwickeltes Cermet mit dem Ziel, den Schleifprozess durch Drehen mit Cermet zu ersetzen.

Doppelstruktur-Hart-Phase

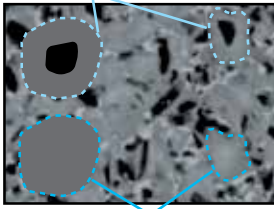

Verbund-Hart-Phase

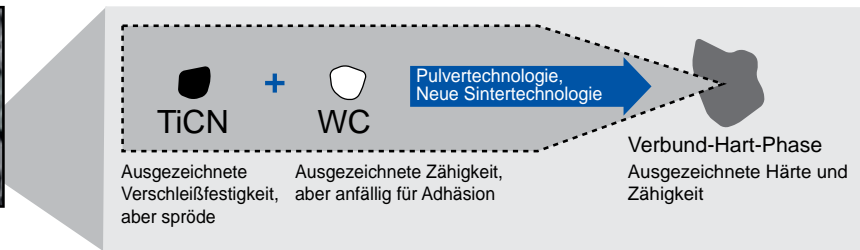

Schnittleistung

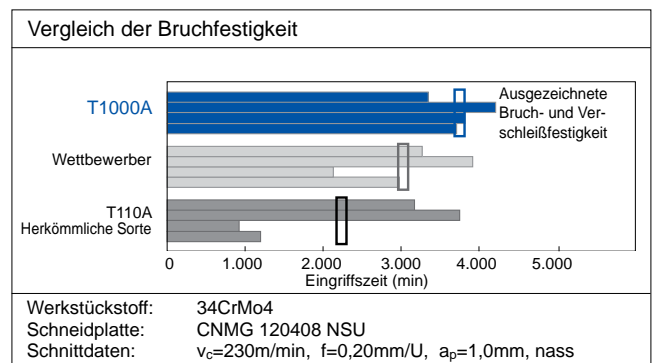
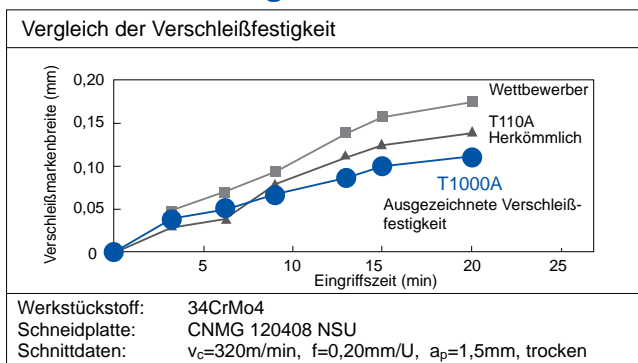

T1500A - Merkmale

Unbeschichtetes Allzweck-Cermet für perfekt geschlichtete Oberflächen in den unterschiedlichsten Drehanwendungen.

- Die Verbundstruktur von harten Bindephasen unterschiedlicher Korngrößen und Zusammensetzung trägt zu einer ausgewogenen Verschleiß- und Bruchbeständigkeit bei.
- Erfolgreicher Einsatz der 3D-Spanbrecher in Bereichen, die eine gute Spankontrolle erfordern.
- Erweiterte Angebotspalette ermöglicht den Einsatz in den vielfältigsten Anwendungen im Schlichtbereich.

Feine TiCN Kornstruktur in der Bindephase
Verbund-Hart-Phase mit grober Kornstruktur

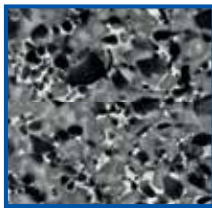

Bindephasenbereich: eng
Feine TiCN-Korngröße, erhöhte Verschleißfestigkeit + Unterdrückung von Risserweiterung

Höhere Verschleißfestigkeit
Verbesserte Bruchfestigkeit

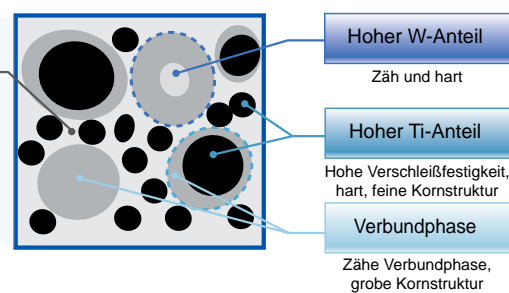

Schnittleistung

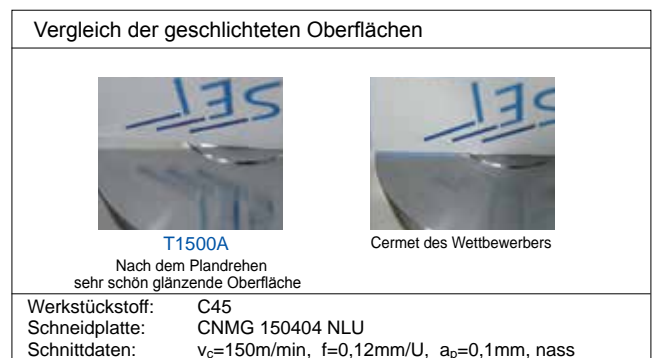
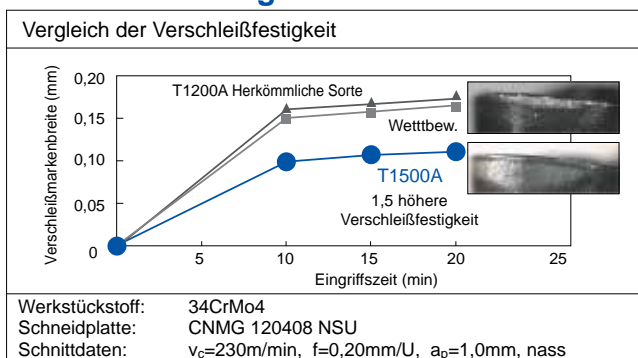

Unbeschichtetes Cermet T1000A / T1500A

Schneidplattenauswahl Negative Schneidplatten

80° Rhombischer Typ, M-Toleranz, Lochplatte

Form	Bezeichnung	Sorte		Abmessungen (mm)						
		T1000A	T1500A	IC	Platten- dicke	Platten- loch Ø	Ecken- radius			
	CNMG 120402 NFA	●	●	12,7	4,76	5,16	0,2			
	120404 NFA	●	●				0,4			
	120408 NFA	●	●				0,8			
	CNMG 120404 NFL	●	●	12,7	4,76	5,16	0,4			
	120408 NFL	●	●				0,8			
	CNMG 090304 NLU		○	9,525	3,18	3,81	0,4			
	090308 NLU		○				0,8			
	CNMG 120402 NLU	○	○				12,7	4,76	5,16	0,2
	120404 NLU	○	○							0,4
	120408 NLU	○	○							0,8
	120412 NLU	○	○	1,2						
	CNMG 120404 NLUW		○	12,7	4,76	5,16	0,4			
	120408 NLUW		○				0,8			
	120412 NLUW		○				1,2			
	CNMG 120402 NSU	○	○	12,7	4,76	5,16	0,2			
	120404 NSU	●	●				0,4			
	120408 NSU	●	●				0,8			
	120412 NSU	●	●				1,2			
	CNMG 120404 NSE	○	○	12,7	4,76	5,16	0,4			
	120408 NSE	○	○				0,8			
	CNMG 120404 NSEW		○	12,7	4,76	5,16	0,4			
	120408 NSEW		○				0,8			
	CNMG 120404 NSX		○	12,7	4,76	5,16	0,4			
	120408 NSX		○				0,8			
	CNMG 120404 NGU		○	12,7	4,76	5,16	0,4			
	120408 NGU		○				0,8			

80° Rhombischer Typ, G-Toleranz, Lochplatte

Form	Bezeichnung	T1000A	T1500A	IC	Platten- dicke	Platten- loch Ø	Ecken- radius
	CNGG 120402 NSU	○	○	12,7	4,76	5,16	0,2
	120404 NSU	○	○				0,4
	120408 NSU	○	○				0,8

55° Rhombischer Typ, M-Toleranz, Lochplatte

Form	Bezeichnung	Sorte		Abmessungen (mm)						
		T1000A	T1500A	IC	Platten- dicke	Platten- loch Ø	Ecken- radius			
	DNMG 150404 NFA	○	○	12,7	4,76	5,16	0,4			
	150408 NFA	○	○				0,8			
	DNMG 150604 NFA	●	●				12,7	6,35	5,16	0,4
150608 NFA	●	●	0,8							
	DNMG 150404 NFL	○	○	12,7	4,76	5,16	0,4			
	150408 NFL	○	○				0,8			
	DNMG 110404 NLU		○	9,525	4,76	3,81	0,4			
	110408 NLU		○				0,8			
	DNMG 150402 NLU	○	○				12,7	4,76	5,16	0,2
	150404 NLU	○	○							0,4
	150408 NLU	○	○							0,8
	150412 NLU	○	○	1,2						
	DNMG 150402 NSU	○	○	12,7	4,76	5,16	0,2			
	150404 NSU	○	○				0,4			
	150408 NSU	○	○				0,8			
	150412 NSU	○	○				1,2			
	DNMG 150604 NSU	●	●				12,7	6,35	5,16	0,4
150608 NSU	●	●	0,8							
150612 NSU	●	●	1,2							
	DNMG 150404 NSE	○	○	12,7	4,76	5,16	0,4			
	150408 NSE	○	○				0,8			
	150412 NSE	○	○				1,2			
	DNMG 150604 NSE	○	○				12,7	6,35	5,16	0,4
150608 NSE	○	○	0,8							
	DNMX 150404 NSEW		○	12,7	4,76	5,16	0,4			
	150408 NSEW		○				0,8			
	DNMG 150404 NSX		○	12,7	4,76	5,16	0,4			
	150408 NSX		○				0,8			
	DNMG 150604 NSX		○	12,7	6,35	5,16	0,4			
	150608 NSX		○				0,8			
	150612 NSX		○				1,2			
	DNMG 150404 NGU		○	12,7	4,76	5,16	0,4			
	150408 NGU		○				0,8			
	150412 NGU		○				1,2			
	DNMG 150404 RUM		○	12,7	4,76	5,16	0,4			
	150404 LUM		○				0,4			
	150408 RUM		○				0,8			
	150408 LUM		○				0,8			

55° Rhombischer Typ, G-Toleranz, Lochplatte

Form	Bezeichnung	Sorte				Abmessungen (mm)			
		T1000A	T1500A	T110A	T1200A	IC	Platten- dicke	Platten- loch Ø	Ecken- radius
	DNGG 150402 NSU	○	○			12,7	4,76	5,16	0,2
	150404 NSU	○	○						0,4
	150408 NSU	○	○						0,8
	DNGG 110404 RUM	○	○			9,525	4,76	3,81	0,4
	110404 LUM	○	○						0,4
	110408 RUM	○	○						0,8
	110408 LUM	○	○						0,8
	DNGG 150404 RUM	○	○						12,7
150404 LUM	○	○			0,4				
150408 RUM	○	○			0,8				
	150408 LUM	○	○			0,8			
	DNGA 150404	○				12,7	4,76	5,16	0,4
	150408	○							0,8

Quadratischer Typ, M-Toleranz, Lochplatte

Form	Bezeichnung	T1000A	T1500A	IC	Platten- dicke	Platten- loch Ø	Ecken- radius			
	SNMG 120408 NFL		○	12,7	4,76	5,16	0,8			
	SNMG 120408 NLU		○	12,7	4,76	5,16	0,8			
	120412 NLU		○				1,2			
	SNMG 120408 NSU	○	○	12,7	4,76	5,16	0,8			
	SNMG 090304 NSJ		○	9,525	3,18	3,81	0,4			
	SNMG 120404 NSJ		○				12,7	4,76	5,16	0,4
	SNMG 120404 NSX		○	12,7	4,76	5,16	0,4			
	120408 NSX		○				0,8			
	SNMG 090308 NGU		○	9,525	3,18	3,81	0,8			
	SNMG 120404 NGU		○				12,7	4,76	5,16	0,4
	120408 NGU		○				0,8			
	SNMG 120404 RUM		○	12,7	4,76	5,16	0,4			
	120404 LUM		○				0,4			
	120408 RUM		○				0,8			
	120408 LUM		○				0,8			
	120412 RUM		○				1,2			
	120412 LUM		○	1,2						



Quadratischer Typ, G-Toleranz, Lochplatte

Form	Bezeichnung	T1000A	T1500A	IC	Platten- dicke	Platten- loch Ø	Ecken- radius
	SNGG 090304 RST	○	○	9,525	3,18	3,81	0,4
	090304 LST	○	○				0,4
	090308 RST	○	○				0,8
	090308 LST	○	○				0,8
	SNGG 120404 RUM	●	●	12,7	4,76	5,16	0,4
	120404 LUM	●	●				0,4
	120408 RUM	●	●				0,8
	120408 LUM	●	●				0,8
	120412 RUM	●	●				1,2
	SNGA 120412	○		12,7	4,76	5,16	1,2







Dreieckiger Typ, M-Toleranz, Lochplatte

Form	Bezeichnung	T1000A	T1500A	IC	Platten- dicke	Platten- loch Ø	Ecken- radius
	TNMG 160402 NFA	●	●	9,525	4,76	3,81	0,2
	160404 NFA	●	●				0,4
	160408 NFA	●	●				0,8
	TNMG 160404 NFL	●	●	9,525	4,76	3,81	0,4
	160408 NFL	●	●				0,8
	TNMG 160402 NLU	○	○	9,525	4,76	3,81	0,2
	160404 NLU	●	●				0,4
	160408 NLU	●	●				0,8
	160412 NLU	●	●				1,2
	TNMG 160402 NSU	○	○	9,525	4,76	3,81	0,2
	160404 NSU	●	●				0,4
	160408 NSU	●	●				0,8
	160412 NSU	●	●				1,2
	TNMG 160404 NSE	○	○	9,525	4,76	3,81	0,4
	160408 NSE	○	○				0,8

 Dreieckiger Typ, M-Toleranz, Lochplatte







Form	Bezeichnung	Sorte		Abmessungen (mm)			
		T1000A	T1500A	IC	Platten- dicke	Platten- loch Ø	Ecken- radius
	TNMG 160404 NSX	○	○	9,525	4,76	3,81	0,4
	160408 NSX	○	○				0,8
	TNMG 160404 NGU		○	9,525	4,76	3,81	0,4
	160408 NGU		○				0,8
	TNMG 160404 RUM	○	○	9,525	4,76	3,81	0,4
	160404 LUM	○	○				0,4
	160408 RUM	○	○				0,8
	160408 LUM	○	○				0,8
	TNMG 220404 RUM		○	12,7	4,76	5,16	0,4
	220404 LUM		○				0,4
	220408 RUM		○				0,8
	220408 LUM		○				0,8

 Dreieckiger Typ, G-Toleranz, Lochplatte

Form	Bezeichnung	Sorte		Abmessungen (mm)						
		T1000A	T1500A	IC	Platten- dicke	Platten- loch Ø	Ecken- radius			
	TNGG 160402 NSU	○	○	9,525	4,76	3,81	0,2			
	160404 NSU	○	○				0,4			
	160408 NSU	○	○				0,8			
	TNGG 160401 RFY	○	○	9,525	4,76	3,81	0,1			
	160401 LFY	○	○				0,1			
	160402 RFY	○	○				0,2			
	160402 LFY	○	○				0,2			
	160404 RFY	○	○				0,4			
	160404 LFY	○	○				0,4			
	160408 RFY	○	○				0,8			
	160408 LFY	○	○				0,8			
	160412 RFY	○	○				1,2			
	160412 LFY	○	○				1,2			
	TNGG 160402 RFX	○	○	9,525	4,76	3,81	0,2			
	160402 LFX	○	○				0,2			
	160404 RFX	○	○				0,4			
	160404 LFX	○	○				0,4			
	TNGG 110302 RFT	○	○	6,35	3,18	2,26	0,2			
	110302 LFT	○	○				0,2			
	110304 RFT	○	○				0,4			
	110304 LFT	○	○				0,4			
	TNGG 160302 RST	○	○	9,525	3,18	3,81	0,2			
	160602 LST	○	○				0,2			
	160304 RST	○	○				0,4			
	160304 LST	○	○				0,4			
	160308 RST	○	○				0,8			
	160308 LST	○	○				0,8			
	TNGG 160402 RST	○	○				9,525	4,76	3,81	0,2
	160402 LST	○	○							0,2
	160404 RST	○	○	0,4						
	160404 LST	○	○	0,4						
	160408 RST	○	○	0,8						
	160408 LST	○	○	0,8						
	160412 RST	○	○	1,2						
	160412 LST	○	○	1,2						
	TNGG 160402 RUM	●	●	9,525	4,76	3,81	0,2			
	160402 LUM	●	●				0,2			
	160404 RUM	●	●				0,4			
	160404 LUM	●	●				0,4			
	160408 RUM	●	●				0,8			
	160408 LUM	●	●				0,8			
	160412 RUM	○	○				1,2			
	160412 LUM	○	○				1,2			
	TNGG 220404 RUM	○	○	12,7	4,76	5,16	0,4			
	220404 LUM	○	○				0,4			
	220408 RUM	○	○				0,8			
	220408 LUM	○	○				0,8			
	TNGA 110308	○					6,35	3,18	2,26	0,8
	TNGA 160404	○					9,525	4,76	3,81	0,4
160408	○	○				0,8				

● Eurolager
○ Japanlager











 35° Rhombischer Typ, M-Toleranz, Lochplatte

Form	Bezeichnung	Sorte		Abmessungen (mm)			
		T1000A	T1500A	IC	Platten- dicke	Platten- loch Ø	Ecken- radius
	VNMG 160404 NFA	○	○	9,525	4,76	3,81	0,4
	160408 NFA	○	○				0,8
	VNMG 160404 NFL	●	●	9,525	4,76	3,81	0,4
	160408 NFL	●	●				0,8
	VNMG 160402 NLU	●	●	9,525	4,76	3,81	0,2
	160404 NLU	●	●				0,4
	160408 NLU	●	●				0,8
	VNMG 160402 NSU	○	○	9,525	4,76	3,81	0,2
	160404 NSU	○	○				0,4
	160408 NSU	○	○				0,8
	VNMG 160404 NSE	○	○	9,525	4,76	3,81	0,4
	160408 NSE	○	○				0,8
	VNMG 160404 NSX		○	9,525	4,76	3,81	0,4
	160408 NSX		○				0,8
	VNMG 160404 NGU		○	9,525	4,76	3,81	0,4
	160408 NGU		○				0,8

 35° Rhombischer Typ, G-Toleranz, Lochplatte

Form	Bezeichnung	Sorte		Abmessungen (mm)			
		T1000A	T1500A	IC	Platten- dicke	Platten- loch Ø	Ecken- radius
	VNMG 160402 NSU	○	○	9,525	4,76	3,81	0,2
	160404 NSU	○	○				0,4
	160408 NSU	○	○				0,8

 Trigon Typ, M-Toleranz, Lochplatte

Form	Bezeichnung	Sorte		Abmessungen (mm)			
		T1000A	T1500A	IC	Platten- dicke	Platten- loch Ø	Ecken- radius
	WNMG 080402 NFA	○	○	12,7	4,76	5,16	0,2
	080404 NFA	●	●				0,4
	080408 NFA	●	●				0,8
	WNMG 080404 NFL	●	●	12,7	4,76	5,16	0,4
	080408 NFL	●	●				0,8
	WNMG 080404 NLU	●	●	12,7	4,76	5,16	0,4
	080408 NLU	●	●				0,8
	080412 NLU		●				1,2
	WNMG 060404 NLUW		●	9,525	4,76	3,81	0,4
	060408 NLUW		●				0,8
	WNMG 080404 NLUW		●	12,7	4,76	5,16	0,4
	080408 NLUW		●				0,8
	080412 NLUW		○				1,2
	WNMG 080404 NSU	●	●	12,7	4,76	5,16	0,4
	080408 NSU	●	●				0,8
	080412 NSU	○	○				1,2
	WNMG 080404 NSE	○	○	12,7	4,76	5,16	0,4
	080408 NSE	○	○				0,8
	WNMG 080404 NSEW		○	12,7	4,76	5,16	0,4
	080408 NSEW		○				0,8
	WNMG 080404 NSX		○	12,7	4,76	5,16	0,4
	080408 NSX		○				0,8
	WNMG 080404 NGU		○	12,7	4,76	5,16	0,4
	080408 NGU		○				0,8

 Trigon Typ, G-Toleranz, Lochplatte

Form	Bezeichnung	Sorte		Abmessungen (mm)			
		T1000A	T1500A	IC	Platten- dicke	Platten- loch Ø	Ecken- radius
	WNMG 080404 NSU	○	○	12,7	4,76	5,16	0,4

 Quadratischer Typ, M-Toleranz, ohne Loch

Form	Bezeichnung	Sorte		Abmessungen (mm)			
		T1000A	T1500A	IC	Platten- dicke	Platten- loch Ø	Ecken- radius
	SNMM 120408	○	○	12,7	4,76		0,8

 Quadratischer Typ, G-Toleranz, ohne Loch

Form	Bezeichnung	Sorte		Abmessungen (mm)			
		T1000A	T1500A	IC	Platten- dicke	Platten- loch Ø	Ecken- radius
	SNGN 120408	○	○	12,7	4,76		0,8

Unbeschichtetes Cermet T1000A / T1500A

Schneidplattenauswahl Positive Schneidplatten

80° Rhombischer Typ, M-Toleranz, Lochplatte

Form	Freiwinkel	Bezeichnung	Sorte		Abmessungen (mm)			
			T1000A	T1500A	IC	Platten- dicke	Platten- loch Ø	Ecken- radius
	7°	CCMT 060202 NFB	●	●	6,35	2,38	2,8	0,2
		CCMT 060204 NFB	●	●	6,35	2,38	2,8	0,4
		CCMT 09T304 NFB	●	●	9,525	3,97	4,4	0,4
	7°	CCMT 09T308 NFB	●	●	9,525	3,97	4,4	0,8
		CCMT 060202 NLB	●	●	6,35	2,38	2,8	0,2
		CCMT 060204 NLB	●	●	6,35	2,38	2,8	0,4
	7°	CCMT 060208 NLB	●	●	6,35	2,38	2,8	0,8
		CCMT 09T302 NLB	●	●	9,525	3,97	4,4	0,2
		CCMT 09T304 NLB	●	●	9,525	3,97	4,4	0,4
	7°	CCMT 09T308 NLB	●	●	9,525	3,97	4,4	0,8
		CCMT 060202 NLU	○	○	6,35	2,38	2,8	0,2
		CCMT 060204 NLU	○	○	6,35	2,38	2,8	0,4
	7°	CCMT 09T304 NLU	○	○	9,525	3,97	4,4	0,4
		CCMT 09T308 NLU	○	○	9,525	3,97	4,4	0,8
		CCMT 09T304 NLUW	○	○	9,525	3,97	4,4	0,4
	7°	CCMT 09T308 NLUW	○	○	9,525	3,97	4,4	0,8
		CCMT 060202 NFP	●	●	6,35	2,38	2,8	0,2
		CCMT 060204 NFP	●	●	6,35	2,38	2,8	0,4
	7°	CCMT 060208 NFP	●	●	6,35	2,38	2,8	0,8
		CCMT 09T302 NFP	●	●	9,525	3,97	4,4	0,2
		CCMT 09T304 NFP	●	●	9,525	3,97	4,4	0,4
	7°	CCMT 09T308 NFP	●	●	9,525	3,97	4,4	0,8
		CCMT 120404 NFP	●	●	12,7	4,76	5,5	0,4
		CCMT 120408 NFP	●	●	12,7	4,76	5,5	0,8
	7°	CCMT 060202 NSU	●	●	6,35	2,38	2,8	0,2
		CCMT 060204 NSU	●	●	6,35	2,38	2,8	0,4
		CCMT 060208 NSU	●	●	6,35	2,38	2,8	0,8
	7°	CCMT 09T302 NSU	●	●	9,525	3,97	4,4	0,2
		CCMT 09T304 NSU	●	●	9,525	3,97	4,4	0,4
		CCMT 09T308 NSU	●	●	9,525	3,97	4,4	0,8
	11°	CPMT 080204 NFB	○	○	7,94	2,38	3,4	0,4
		CPMT 090304 NFB	○	○	9,525	3,18	4,4	0,4
		CPMT 090308 NFB	○	○	9,525	3,18	4,4	0,8
	11°	CPMT 090304 NLB	○	○	9,525	3,18	4,4	0,4
		CPMT 090308 NLB	○	○	9,525	3,18	4,4	0,8
		CPMT 080204 NLU	○	○	7,94	2,38	3,4	0,4
	11°	CPMT 090304 NLU	○	○	9,525	3,18	4,4	0,4
		CPMT 090308 NLU	○	○	9,525	3,18	4,4	0,8
		CPMT 090304 NLUW	○	○	9,525	3,18	4,4	0,4
	11°	CPMT 090308 NLUW	○	○	9,525	3,18	4,4	0,8
		CPMT 080204 NSU	○	○	7,94	2,38	3,4	0,4
		CPMT 080208 NSU	○	○	7,94	2,38	3,4	0,8
	11°	CPMT 090304 NSU	○	○	9,525	3,18	4,4	0,4
		CPMT 090308 NSU	○	○	9,525	3,18	4,4	0,8

80° Rhombischer Typ, G-Toleranz, Lochplatte

Form	Freiwinkel	Bezeichnung	Sorte		Abmessungen (mm)			
			T1000A	T1500A	IC	Platten- dicke	Platten- loch Ø	Ecken- radius
	7°	CCGT 090301 M NSC	○	○	9,525	3,18	4,4	<0,1
		CCGT 090302 M NSC	○	○	9,525	3,18	4,4	<0,2
		CCGT 09T301 M NSC	●	●	9,525	3,97	4,4	<0,1
	7°	CCGT 09T302 M NSC	●	●	9,525	3,97	4,4	<0,2
		CCGT 09T304 M NSC	●	●	9,525	3,97	4,4	<0,4
		CCGT 09T308 M NSC	●	●	9,525	3,97	4,4	<0,8
	11°	CPGT 080202 NSD	●	●	7,94	2,38	3,4	0,2
		CPGT 080204 NSD	●	●	7,94	2,38	3,4	0,4
		CPGT 080208 NSD	○	○	7,94	2,38	3,4	0,8
	11°	CPGT 090302 NSD	○	○	9,525	3,18	4,4	0,2
		CPGT 090304 NSD	○	○	9,525	3,18	4,4	0,4
		CPGT 090308 NSD	○	○	9,525	3,18	4,4	0,8
	11°	CPGT 120402 NSD	○	○	12,7	4,76	5,5	0,2
		CPGT 120404 NSD	○	○	12,7	4,76	5,5	0,4
		CPGT 120408 NSD	○	○	12,7	4,76	5,5	0,8

80° Rhombischer Typ, E-Toleranz, Lochplatte

Form	Freiwinkel	Bezeichnung	Sorte		Abmessungen (mm)			
			T1000A	T1500A	IC	Platten- dicke	Platten- loch Ø	Ecken- radius
	7°	CCET 03X1003 RFY	○	○	3,5	1,4	1,8	0,03
		CCET 03X1003 LFY	○	○				0,03
		CCET 03X101 RFY	○	○				0,1
		CCET 03X101 LFY	○	○				0,1
		CCET 03X102 RFY	○	○				0,2
		CCET 03X102 LFY	○	○				0,2
		CCET 03X104 RFY	○	○	0,4			
		CCET 03X104 LFY	○	○	0,4			
		CCET 04X1003 RFY	○	○	4,3	1,8	2,2	0,03
		CCET 04X1003 LFY	○	○				0,03
		CCET 04X101 RFY	○	○				0,1
		CCET 04X101 LFY	○	○				0,1
		CCET 04X102 RFY	○	○				0,2
		CCET 04X102 LFY	○	○				0,2
		CCET 04X104 RFY	○	○	0,4			
CCET 04X104 LFY	○	○	0,4					
CCET 060201 RFY	○	○	6,35	2,38	2,8	0,1		
CCET 060201 LFY	○	○				0,1		
CCET 060202 RFY	○	○				0,2		
CCET 060202 LFY	○	○	0,2					
CCET 09T301 RFY	○	○	9,525	3,97	4,4	0,1		
CCET 09T301 LFY	○	○				0,1		
CCET 09T302 RFY	○	○				0,2		
CCET 09T302 LFY	○	○	0,2					

80° Rhombischer Typ, G-Toleranz, Lochplatte

Form	Freiwinkel	Bezeichnung	Sorte		Abmessungen (mm)			
			T1000A	T1500A	IC	Platten- dicke	Platten- loch Ø	Ecken- radius
	7°	CCGT 060201 M NFC	○	○	6,35	2,38	2,8	<0,1
		CCGT 060202 M NFC	○	○				<0,2
		CCGT 060204 M NFC	○	○				<0,4
	7°	CCGT 09T301 M NFC	○	○	9,525	3,97	4,4	<0,1
		CCGT 09T302 M NFC	○	○				<0,2
		CCGT 09T304 M NFC	○	○				<0,4
	7°	CCGT 060201 RFX	●	●	6,35	2,38	2,8	0,1
		CCGT 060201 LFX	●	●				0,1
		CCGT 060202 RFX	●	●				0,2
		CCGT 060202 LFX	●	●				0,2
		CCGT 060204 RFX	●	●				0,4
		CCGT 060204 LFX	●	●				0,4
	7°	CCGT 09T301 RFX	●	●	9,525	3,97	4,4	0,1
		CCGT 09T301 LFX	●	●				0,1
		CCGT 09T302 RFX	●	●				0,2
		CCGT 09T302 LFX	●	●				0,2
		CCGT 09T304 RFX	●	●				0,4
		CCGT 09T304 LFX	●	●				0,4
	7°	CCGT 09T301 M NSI	○	○	9,525	3,97	4,4	<0,1
		CCGT 09T302 M NSI	○	○				<0,2
		CCGT 09T304 M NSI	○	○				<0,4
	7°	CCGT 0602003 NSC	○	○	6,35	2,38	2,8	0,03
		CCGT 060201 M NSC	●	●				<0,1
		CCGT 060202 M NSC	●	●				<0,2
		CCGT 060204 M NSC	●	●				<0,4
		CCGT 080201 M NSC	○	○				<0,1
CCGT 080202 M NSC	○	○	<0,2					

55° Rhombischer Typ, M-Toleranz, Lochplatte

Form	Freiwinkel	Bezeichnung	Sorte		Abmessungen (mm)			
			T1000A	T1500A	IC	Platten- dicke	Platten- loch Ø	Ecken- radius
	7°	DCMT 070202 NFB	●	●	6,35	2,38	2,8	0,2
		DCMT 070204 NFB	●	●				0,4
		DCMT 070208 NFB	●	●				0,8
	7°	DCMT 11T302 NFB	●	●	9,525	3,97	4,4	0,2
		DCMT 11T304 NFB	●	●				0,4
		DCMT 11T308 NFB	●	●				0,8
	7°	DCMT 070202 NLB	●	●	6,35	2,38	2,8	0,2
		DCMT 070204 NLB	●	●				0,4
		DCMT 070208 NLB	●	●				0,8
	7°	DCMT 11T302 NLB	●	●	9,525	3,97	4,4	0,2
		DCMT 11T304 NLB	●	●				0,4
		DCMT 11T308 NLB	●	●				0,8
	7°	DCMT 070202 NLU	○	○	6,35	2,38	2,8	0,2
		DCMT 070204 NLU	○	○				0,4
		DCMT 11T302 NLU	○	○				0,2
	7°	DCMT 11T304 NLU	○	○	9,525	3,97	4,4	0,4
		DCMT 11T308 NLU	○	○				0,8
		DCMT 11T302 NLU	○	○				0,2
	7°	DCMT 070202 NFP	●	●	6,35	2,38	2,8	0,2
		DCMT 070204 NFP	●	●				0,4
		DCMT 11T302 NFP	●	●				0,2
	7°	DCMT 11T304 NFP	●	●	9,525	3,97	4,4	0,4
		DCMT 11T308 NFP	●	●				0,8
		DCMT 11T312 NFP	●	●				1,2
	7°	DCMT 070202 NSU	●	●	6,35	2,38	2,8	0,2
		DCMT 070204 NSU	●	●				0,4
		DCMT 070208 NSU	○	○				0,8
	7°	DCMT 11T302 NSU	○	○	9,525	3,97	4,4	0,2
		DCMT 11T304 NSU	○	○				0,4
		DCMT 11T308 NSU	○	○				0,8

◇ 55° Rhombischer Typ, G-Toleranz, Lochplatte

Form	Freiwinkel	Bezeichnung	Sorte		Abmessungen (mm)					
			T1000A	T1500A	IC	Platten- dicke	Platten- loch Ø	Ecken- radius		
	7°	DCGT 070201 M NFC	○	○	6,35	2,38	2,8	<0,1		
		070202 M NFC	○	○				<0,2		
		070204 M NFC	○	○				<0,4		
	7°	DCGT 11T301 M NFC	○	○	9,525	3,97	4,4	<0,1		
		11T302 M NFC	○	○				<0,2		
		11T304 M NFC	○	○				<0,4		
	7°	DCGT 070201 RFX	●	●	6,35	2,38	2,8	0,1		
		070201 LFX	●	●				0,1		
		070202 RFX	●	●				0,2		
		070202 LFX	●	●				0,2		
		070204 RFX	●	●				0,4		
		070204 LFX	●	●				0,4		
		DCGT 11T301 RFX	●	●	9,525	3,97	4,4	0,1		
		11T301 LFX	●	●				0,1		
		11T302 RFX	●	●				0,2		
		11T302 LFX	●	●				0,2		
		11T304 RFX	●	●				0,4		
		11T304 LFX	●	●				0,4		
			7°	DCGT 070202 RSD	○	○	6,35	2,38	2,8	0,2
				070202 LSD	○	○				0,2
				070204 RSD	○	○				0,4
070204 LSD	○			○	0,4					
DCGT 11T304 RSD	○			○	9,525	3,97	4,4	0,4		
11T304 LSD	○			○				0,4		
11T308 RSD	○	○	0,8							
11T308 LSD	○	○	0,8							
	7°	DCGT 070201 M NSI	○	○	6,35	2,38	2,8	<0,1		
		070202 M NSI	○	○				<0,2		
		070204 M NSI	○	○				<0,4		
		DCGT 11T301 M NSI	○	○	9,525	3,97	4,4	<0,1		
		11T302 M NSI	○	○				<0,2		
		11T304 M NSI	○	○				<0,4		
		11T308 M NSI	○	○	<0,8					

◇ 55° Rhombischer Typ, G-Toleranz, Lochplatte

	7°	DCGT 0702003 NSC	○	○	6,35	2,38	2,8	0,03
		DCGT 070201 M NSC	●	●				<0,1
		070202 M NSC	●	●				<0,2
		070204 M NSC	●	●	<0,4			
		DCGT 090201 M NSC	○	○	7,94	2,38	3,4	<0,1
		090202 M NSC	○	○				<0,2
		DCGT 110301 M NSC	○	○				<0,1
		110302 M NSC	●	●	9,525	3,18	4,4	<0,2
		DCGT 11T3003 NSC	○	○				0,03
		DCGT 11T301 M NSC	●	●	9,525	3,97	4,4	<0,1
		11T302 M NSC	●	●				<0,2
		11T304 M NSC	●	●				<0,4
		11T308 M NSC	●	●				<0,8

○ Quadratischer Typ, M-Toleranz, Lochplatte

	7°	SCMT 09T304 NFB	○	○	9,525	3,97	4,4	0,4
		09T308 NFB	○	○				0,8
	7°	SCMT 09T304 NLU	○	○	9,525	3,97	4,4	0,4
		09T308 NLU	○	○				0,8
	7°	SCMT 09T304 NFP	●	●	9,525	3,97	4,4	0,4
		09T308 NFP	●	●				0,8
		SCMT 120404 NFP		○				12,7
120408 NFP		○	0,8					
	11°	SPMT 090304 NFB	○	○	9,525	3,18	3,4	0,4
		090308 NFB	○	○				0,8
	11°	SPMT 090304 NLU	○	○	9,525	3,18	3,4	0,4
		090308 NLU	○	○				0,8

○ Quadratischer Typ, G-Toleranz, Lochplatte

Form	Freiwinkel	Bezeichnung	Sorte		Abmessungen (mm)					
			T1000A	T1500A	IC	Platten- dicke	Platten- loch Ø	Ecken- radius		
	7°	SCGT 070201 M NSC	○	○	7,94	2,38	3,4	<0,1		
		070202 M NSC	○	○				<0,2		
		SCGT 090301 M NSC	○	○	9,525	3,18	4,4	<0,1		
		090302 M NSC	○	○				<0,2		
	11°	SCGT 09T301 M NSC	○	○	9,525	3,97	4,4	<0,1		
		09T302 M NSC	○	○				<0,2		
		SPGT 090302 RSD	11°	090302 LSD	○	○	9,525	3,18	3,4	0,2
				090304 RSD	○	○				0,2
090304 LSD	○			○	0,4					
090308 RSD	○			○	0,8					
090308 LSD	○	○	0,8							
SPGW 090304 T	11°		●		9,525	3,18	3,4	0,4		

△ Dreieckiger Typ, M-Toleranz, Lochplatte

	7°	TCMT 110204 NFB	●	●	6,35	2,38	2,8	0,4
		110208 NFB	●	●				0,8
	7°	TCMT 110204 NLU	○	○	6,35	2,38	2,8	0,4
		110208 NLU	○	○				0,8
	7°	TCMT 090202 NFP		●	5,56	2,38	2,5	0,2
		090204 NFP		●				0,4
		090208 NFP		●				0,8
		TCMT 110202 NFP		●	6,35	2,38	2,8	0,2
		110204 NFP		●				0,4
		110208 NFP		●				0,8
TCMT 16T304 NFP		●	9,525	3,97	4,3	0,4		
16T308 NFP		●				0,8		
	11°	TPMT 080202 NFB	○	○	4,76	2,38	2,4	0,2
		080204 NFB	○	○				0,4
		TPMT 090202 NFB	○	○	5,56	2,38	2,8	0,2
		090204 NFB	○	○				0,4
	11°	TPMT 110302 NFB	○	○	6,35	3,18	3,4	0,2
		110304 NFB	○	○				0,4
		110308 NFB	○	○				0,8
		TPMT 160304 NFB	○	○	9,525	3,18	4,4	0,4
		160308 NFB	○	○				0,8
		TPMT 160404 NFB	○	○				9,525
160408 NFB	○	○	0,8					
	11°	TPMT 090202 NLB		○	5,56	2,38	2,8	0,2
		090204 NLB		○				0,4
		TPMT 110302 NLB		○	6,35	3,18	3,4	0,2
		110304 NLB		○				0,4
110308 NLB		○	0,8					
	11°	TPMT 080202 NLU	○	○	4,76	2,38	2,4	0,2
		080204 NLU	○	○				0,4
		TPMT 090202 NLU	○	○	5,56	2,38	2,8	0,2
		090204 NLU	○	○				0,4
TPMT 110302 NLU	○	○	6,35	3,18				3,4
110304 NLU	○	○			0,4			
110308 NLU	○	○			0,8			
	11°	TPMT 110304 NFK	●	●	6,35	3,18	3,4	0,4
		110308 NFK	●	●				0,8
		TPMT 160404 NFK	●	●	9,525	4,76	4,4	0,4
		160408 NFK	●	●				0,8
	11°	TPMT 080202 NSU	○	○	4,76	2,38	2,4	0,2
		080204 NSU	○	○				0,4
		TPMT 110302 NSU	○	○	6,35	3,18	3,4	0,2
		110304 NSU	○	○				0,4
		110308 NSU	○	○				0,8
		TPMT 160404 NSU	○	○	9,525	4,76	4,4	0,4
160408 NSU	○	○	0,8					

● Eurolager
○ Japanlager

Hinweis: Einige Platten haben einen Schneidradius mit Minus-Toleranz (M).

DCGT 11T304 M NSI

„M“ = Minus-Toleranz

Unbeschichtetes Cermet T1000A / T1500A

Schneidplattenauswahl Positive Schneidplatten

△ Dreieckiger Typ, G-Toleranz, Lochplatte

Form	Freiwinkel	Bezeichnung	Sorte		Abmessungen (mm)				
			T1000A	T1500A	IC	Platten- dicke	Platten- loch Ø	Ecken- radius	
	5°	TBGT 060102 RFW		○	3,97	1,59	2,2	0,2	
		060102 LFW		○				0,2	
		060104 RFW		○				0,4	
		060104 LFW		○				0,4	
	5°	TBGT 060102 RFY	○	○	3,97	1,59	2,2	0,2	
		060102 LFY	○	○				0,2	
		060104 RFY	○	○				0,4	
		060104 LFY	○	○				0,4	
	5°	TBGT 060102 RW	○	●	3,97	1,59	2,2	0,2	
		060102 LW	○	●				0,2	
		060104 RW	○	●				0,4	
		060104 LW	○	●				0,4	
	5°	TBGW 060102		○	3,97	1,59	2,2	0,2	
		060104		○				0,4	
	7°	TCGT 080201 M NSC	○	○	4,76	2,38	2,3	<0,1	
		080202 M NSC	○	○				<0,2	
		TCGT 090201 M NSC	○	○	5,56	2,38	2,5	<0,1	
		090202 M NSC	●	●				<0,2	
		TCGT 110201 M NSC	○	○	6,35	2,38	2,8	<0,1	
		110202 M NSC	●	●				<0,2	
110204 M NSC	○	●	<0,4						
TCGT 110301 M NSC	○	○	6,35	3,18	2,8	<0,1			
110302 M NSC	○	○				<0,2			
	11°	TPGT 110302 M NFC	○	○	6,35	3,18	3,4	<0,2	
		110304 M NFC	○	○				<0,4	
	11°	TPGT 080202 RFW	○	○	4,76	2,38	2,4	0,2	
		080202 LFW	○	○				0,2	
		080204 RFW	○	○				0,4	
		080204 LFW	○	○				0,4	
	TPGT 110202 RFW	○	○	6,35	2,38	2,8	0,2		
	110202 LFW	○	○				0,2		
	110204 RFW	○	○				0,4		
	110204 LFW	○	○				0,4		
	11°	TPGT 090204 LFX	○	○	5,56	2,38	2,8	0,4	
	11°	TPGT 080202 RFY	○	○	4,76	2,38	2,4	0,2	
		080202 LFY	○	○				0,2	
		080204 RFY	○	○				0,4	
		080204 LFY	○	○				0,4	
		TPGT 110202 RFY	○	○	6,35	2,38	2,8	0,2	
		110202 LFY	○	○				0,2	
		110204 RFY	○	○				0,4	
		110204 LFY	○	○				0,4	
	TPGT 110208 RFY		○				0,8		
	110208 LFY		○				0,8		
	TPGT 110302 RFY	○	○	6,35	3,18	3,4	0,2		
	110302 LFY	○	○				0,2		
	110304 RFY	○	○				0,4		
	110304 LFY	○	○				0,4		
110308 RFY		○							0,8
110308 LFY		○							0,8
11°	TPGT 080202 RW		●	4,76	2,38	2,4	0,2		
			●				0,2		
			●				0,4		
			●				0,4		
	TPGT 110302 RW		●	6,35	3,18	3,4	0,2		
			●				0,2		
			●				0,4		
			●				0,4		
TPGT 160402 LW		●	9,525	4,76	4,4	0,2			
		●				0,4			
		●				0,4			
		●				0,4			

△ Dreieckiger Typ, G-Toleranz, Lochplatte

Form	Freiwinkel	Bezeichnung	Sorte		Abmessungen (mm)			
			T1000A	T1500A	IC	Platten- dicke	Platten- loch Ø	Ecken- radius
	11°	TPGT 110302 RSD	○	●	6,35	3,18	3,4	0,2
		110302 LSD	○	●				0,2
		110304 RSD	○	●				0,4
		110304 LSD	○	●				0,4
		110308 RSD	○	○				0,8
		110308 LSD	○	○	0,8			
		TPGT 160402 RSD	○	○	9,525	4,76	4,4	0,2
		160402 LSD	○	●				0,2
		160404 RSD	○	●				0,4
		160404 LSD	○	●				0,4
160408 RSD	○	●	0,8					
160408 LSD	○	○	0,8					
	11°	TPGX 160404 R SDW		○	9,525	4,76	4,4	0,4
		160404 L SDW		○				0,4
		160408 R SDW		○				0,8
		160408 L SDW		○				0,8
	11°	TPGW 080202	○	○	4,76	2,38	2,4	0,2
		TPGW 110304	○	○				0,4
		110308	○	○				0,8

◇ 35° Rhombischer Typ, M-Toleranz, Lochplatte

	5°	VBMT 110302 NFB	○	○	6,35	3,18	2,8	0,2
		110304 NFB	○	○				0,4
		110308 NFB	○	○				0,8
		VBMT 160404 NFB	●	●	9,525	4,76	4,4	0,4
160408 NFB	●	●	0,8					
	5°	VBMT 110202 NFP	●	●	6,35	2,38	2,8	0,2
		110204 NFP	●	●				0,4
		VBMT 160404 NFP	●	●	9,525	4,76	4,4	0,4
		160408 NFP	●	●				0,8
	5°	VBMT 160404 NLB		●	9,525	4,76	4,4	0,4
		160408 NLB		●				0,8
		160412 NLB		●				1,2
	5°	VBMT 110302 NLU	○	○	6,35	3,18	2,8	0,2
		110304 NLU	○	○				0,4
		VBMT 160404 NLU	○	○				9,525
160408 NLU	○	○	0,8					
	5°	VBMT 160404 NSU	○	○	9,525	4,76	4,4	0,4
		160408 NSU	○	○				0,8
	7°	VCMT 080202 NFB	○	○	4,76	2,38	2,3	0,2
		080204 NFB	○	○				0,4
		VCMT 160404 NFB	○	○	9,525	4,76	4,4	0,4
		160408 NFB	○	○				0,8
	7°	VCMT 160404 NLU	○	○	9,525	4,76	4,4	0,4
		160408 NLU	○	○				0,8





● Eurolager
○ Japanlager

Hinweis: Einige Platten haben einen Schneidradius mit Minus-Toleranz (M).



DCGT 11T304 M NSI

„M“ = Minus-Toleranz



 35° Rhombischer Typ, G-Toleranz, Lochplatte

Form	Freiwinkel	Bezeichnung	Sorte		Abmessungen (mm)			Eckenradius			
			T1000A	T1500A	IC	Platten- dicke	Platten- loch Ø				
	5°	VBGT 110301 RFX	○	○	6,35	3,18	2,8	0,1			
		110301 LFX	○	○				0,1			
		110302 RFX	○	○				0,2			
		110302 LFX	○	○				0,2			
		110304 RFX	○	○				0,4			
VBGT 160402 RFX	○	○	○	○	9,525	4,76	4,4	0,2			
								160402 LFX	○	○	0,2
								160404 RFX	○	○	0,4
								160404 LFX	○	○	0,4
	5°	VBGT 110301 RFY	○	○	6,35	3,18	2,8	0,1			
		110301 LFY	○	○				0,1			
		110302 RFY	○	○				0,2			
		110302 LFY	○	○				0,2			
	7°	VCGT 110301 M NFC	○	○	6,35	3,18	2,8	<0,1			
		110302 M NFC	○	○				<0,2			
		110304 M NFC	○	○				<0,4			
	7°	VCGT 110301 RFX	○	●	6,35	3,18	2,8	0,1			
		110301 LFX	○	●				0,1			
		110302 RFX	○	●				0,2			
		110302 LFX	○	●				0,2			
	7°	VCGT 110301 M NSI	○	○	6,35	3,18	2,8	<0,1			
		110302 M NSI	○	○				<0,2			
		110304 M NSI	○	○				<0,4			
		110308 M NSI	○	○				<0,8			
		VCGT 160401 M NSI	○	○				<0,1			
		160402 M NSI	○	○				9,525	4,76	4,4	<0,2
		160404 M NSI	○	○				<0,4			

 Trigon Typ, G-Toleranz, Lochplatte

	5°	WBGT 060102 RFW	○	○	3,97	1,59	2,2	0,2	
		060102 LFW	○	○				0,2	
		060104 RFW	○	○				0,4	
		060104 LFW	○	○				0,4	
		WBGT 080202 RFW	○	○				4,76	2,38
080202 LFW	○	○	0,2						
080204 RFW	○	○	0,4						
080204 LFW	○	○	0,4						
WBGT 0601003 LFY	○	○	3,97	1,59	2,2	0,03			
060101 RFY	○	○				0,1			
060101 LFY	○	○				0,1			
060102 RFY	○	○				0,2			
060102 LFY	○	○				0,2			
060104 RFY	○	○				0,4			
060104 LFY	○	○				0,4			
WBGT 080201 RFY	○	○				4,76	2,38	2,4	0,1
080201 LFY	○	○							0,1
080202 RFY	○	○							0,2
080202 LFY	○	○	0,2						
080204 RFY	○	○	0,4						
080204 LFY	○	○	0,4						
	5°	WBGT 060102 RW	○	●	3,97	1,59	2,2	0,2	
		060102 LW	○	●				0,2	
		060104 RW	○	●				0,4	
		060104 LW	○	●				0,4	
	11°	WPMT 110204 NLB	○	○	6,35	2,38	2,8	0,4	
		WPMT 160308 NLB	○	○	9,525	3,18	4,4	0,8	



 Quadratischer Typ, M-Toleranz, ohne Loch

Form	Freiwinkel	Bezeichnung	Sorte		Abmessungen (mm)			Eckenradius
			T1000A	T1500A	IC	Platten- dicke	Platten- loch Ø	
	11°	SPMR 090304 NFK	○	●	9,525	3,18	-	0,4
		090308 NFK	○	○				0,8
		SPMR 120304 NFK	○	○				12,7
120308 NFK	○	○	0,8					
	11°	SPMN 090304	○	○	9,525	3,18	-	0,4
		090308	○	○				0,8
		SPMN 120308	○	○				12,7
120312	○	○	1,2					





 Quadratischer Typ, G-Toleranz, ohne Loch

	11°	SPGN 090304	○	●	9,525	3,18	-	0,4			
		090308	○	●				0,8			
		SPGN 120304	○	○				12,7	3,18	-	0,4
		120308	○	○							0,8

 Dreieckiger Typ, M-Toleranz, ohne Loch

	11°	TPMR 090204 NFK	○	○	6,35	3,18	-	0,4
		110302 NFK	○	○				0,2
		110304 NFK	○	○				0,4
		110308 NFK	○	○				0,8
		TPMR 160304 NFK	○	○				9,525
160308 NFK	○	○	0,8					
160312 NFK	○	○	1,2					
	11°	TPMN 160308	○	○	9,525	3,18	-	0,8
		TPMN 220408	○	○				12,7

 Dreieckiger Typ, G-Toleranz, ohne Loch

	5°	TBGR 060104 LW	○	○	3,97	1,59	-	0,4			
	5°	TBGN 060104	○	○	3,97	1,59	-	0,4			
	11°	TPGR 090202 RW	○	○	5,56	2,38	-	0,2			
		090202 LW	○	○				0,2			
		090204 RW	○	○				0,4			
		090204 LW	○	○				0,4			
		090208 RW	○	○				0,8			
		090208 LW	○	○				0,8			
	TPGR 110302 RW	○	○	6,35	3,18	-	0,2				
	110302 LW	○	○				0,2				
	110304 RW	○	●				0,4				
	110304 LW	○	●				0,4				
	110308 RW	○	○				0,8				
	110308 LW	○	○				0,8				
TPGR 160302 RW	○	○	○	○	9,525	3,18	-	0,2			
								160302 LW	○	○	0,2
								160304 RW	○	●	0,4
								160304 LW	○	●	0,4
								160308 RW	○	●	0,8
								160308 LW	○	●	0,8
	11°	TPGN 090202	○	○	5,56	2,38	-	0,2			
		090204	○	○				0,4			
		090208	○	○				0,8			
		TPGN 110302	○	○				6,35	3,18	-	0,2
		110304	○	○							0,4
		110308	○	○							0,8
TPGN 160302	○	○	9,525	3,18	-	0,2					
160304	○	○				0,4					
160308	○	○				0,8					
	20°	TEGN 160308	○	○	9,525	3,18	-	0,8			

Unbeschichtetes Cermet T1000A / T1500A

Empfohlene Schnittbedingungen

Werkstückstoff	Anwendung	Spanbrecher	Sorte	Schnittbedingungen		
				Schnitttiefe a_p (mm)	Vorschub f (mm/U)	Schnittgeschwindigk. v_c (m/min)
Baustahl	Feinstschichten	R/LFY / R/LFX	T1000A	0,1 - 0,4 - 0,8	0,04 - 0,10 - 0,20	150 - 280 - 400
	Feinstschichten ~ Schichten	NFL	T1500A	0,2 - 0,5 - 1,0	0,05 - 0,15 - 0,25	150 - 280 - 400
Kohlenstoffstahl, Legierter Stahl	Feinstschichten	R/LFY / NFA	T1000A	0,1 - 0,4 - 0,8	0,04 - 0,10 - 0,20	100 - 200 - 300
	Schichten	NSU / NSE	T1500A	0,5 - 1,0 - 2,0	0,08 - 0,20 - 0,35	100 - 200 - 300
	Mittel	NGU	T1500A	0,8 - 2,2 - 4,0	0,15 - 0,25 - 0,50	100 - 200 - 300
Stahl mit hohem Kohlenstoffgehalt, Legierter Stahl	Feinstschichten	NFA	T1000A	0,2 - 0,5 - 1,0	0,05 - 0,15 - 0,25	50 - 150 - 250
	Schichten	NSU / NSE	T1500A	0,5 - 1,0 - 2,0	0,08 - 0,20 - 0,35	50 - 150 - 250
	Mittel	NGU	T1500A	0,8 - 2,2 - 4,0	0,15 - 0,25 - 0,50	50 - 150 - 250

Schneidplatten für Mini-Werkzeughalter SBT-Typ / PBT-Typ

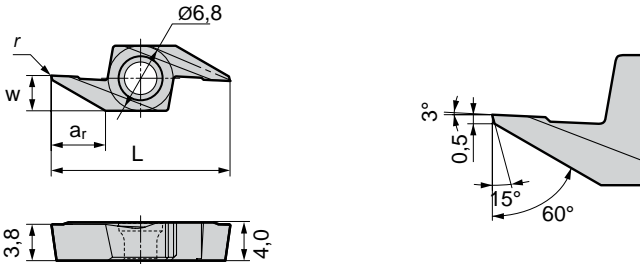
						Geeigneter Werkzeughalter
	Bezeichnung	Lager	Abmessungen (mm)			
	T1500A	L	a_r	w	r	
BTR 3505	●	15	3,5	2,5	0,05	SBT35R□□□□
BTR 3515	●	15	3,5	2,5	0,15	PBT35R□□□□

● Eurolager

Unbeschichtetes Cermet T1500A

Anwendungsbeispiele

T1500A – M-Toleranz

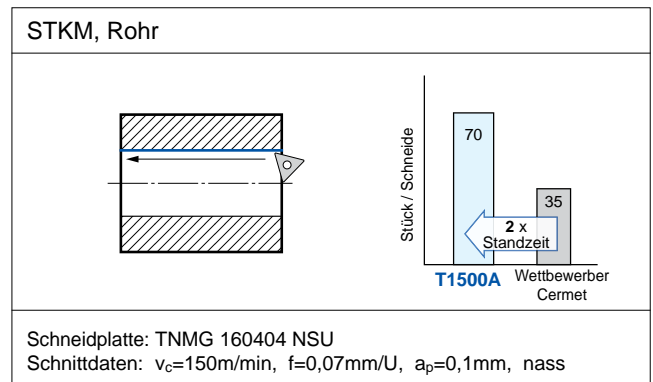
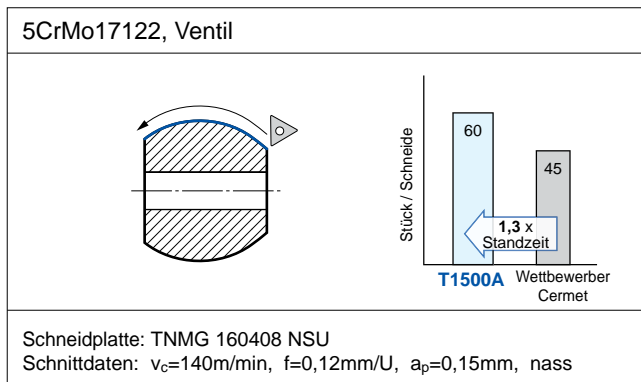
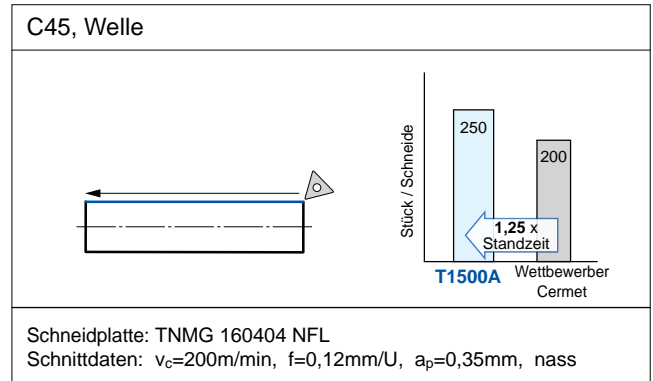
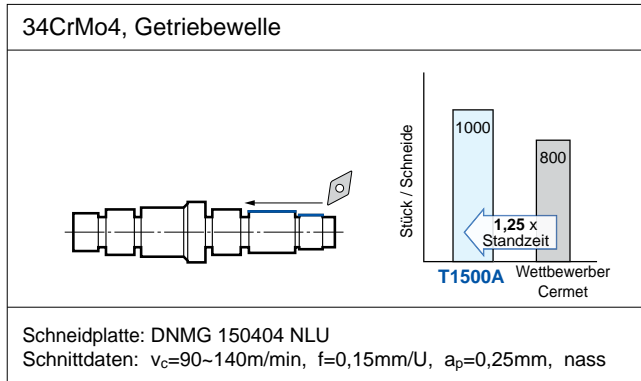

T1500A – G-Toleranz

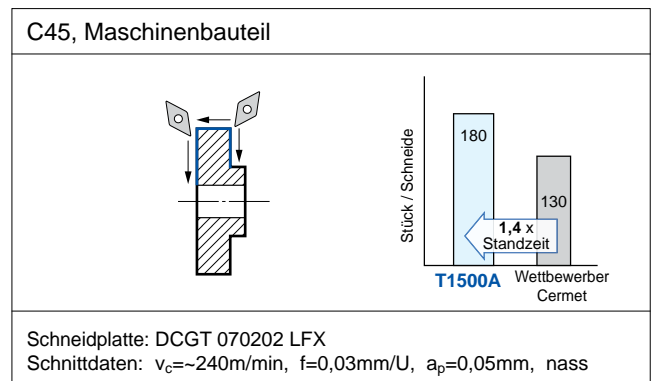
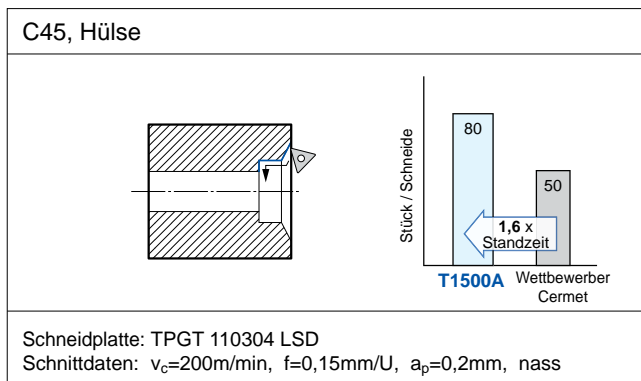
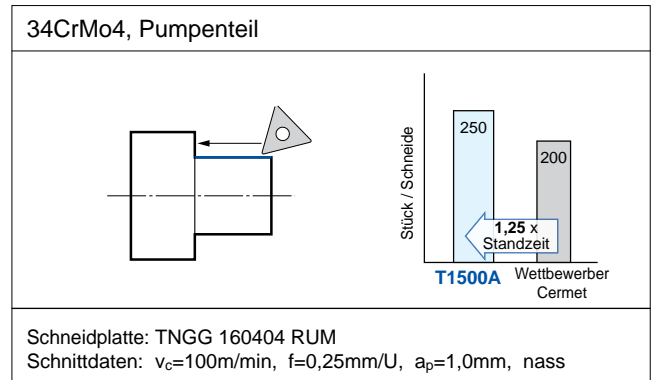
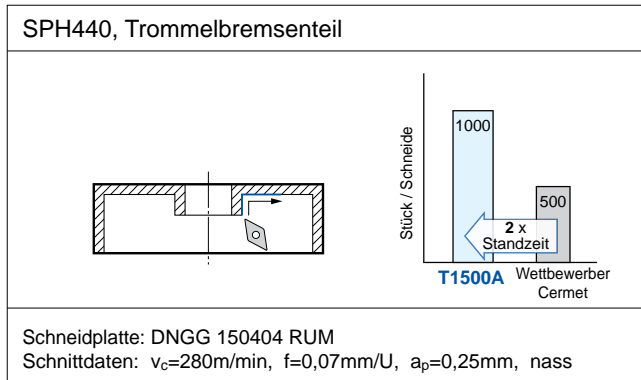

Unbeschichtetes Cermet T1000A

■ Anwendungsbeispiele

T1000A – M-Toleranz

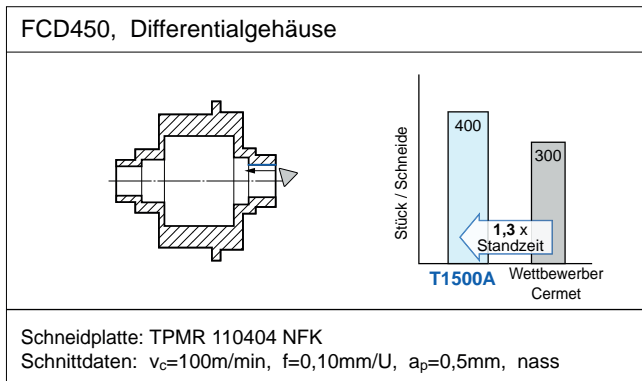
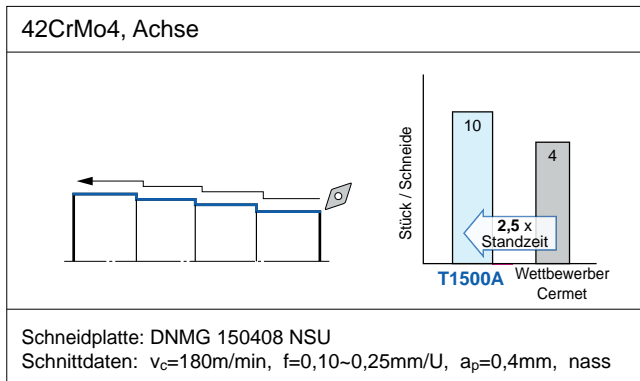

T1000A – G-Toleranz

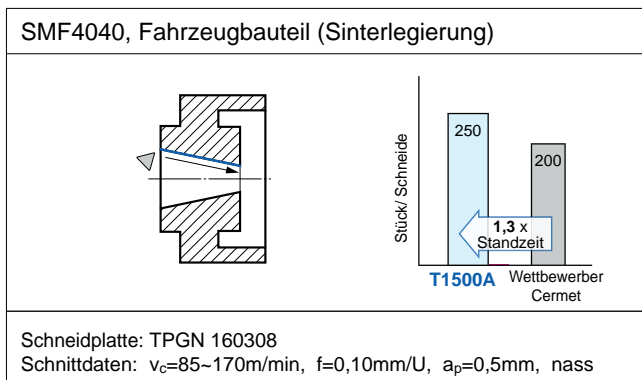
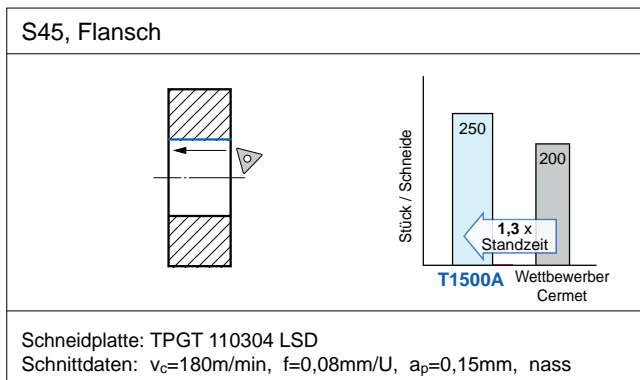

SUMITOMO ELECTRIC Hartmetall GmbH
Siemensring 84, D - 47877 Willich

Tel. +49(0)2154 4992-0, Fax +49(0)2154 41072, E-mail: Info@SumitomoTool.com Internet: www.SumitomoTool.com



Vertretung:



MAS GmbH
Postfach 1840 · 71208 Leonberg
Glemseckstraße 69 · 71229 Leonberg

Tel. +49 7152-6065-0
Fax +49 7152-6065-65

zentrale@mas-tools.de
www.mas-tools.de

